

TS80-2

Caption

weight	approximate weight	price	price
core	core type	f_{zas}	operating frequency
P_{max}	maximum power	U_{we}	input voltage
$U_{n/In}$	output voltage for current	sizes	overall dimensions

Specyfikacje

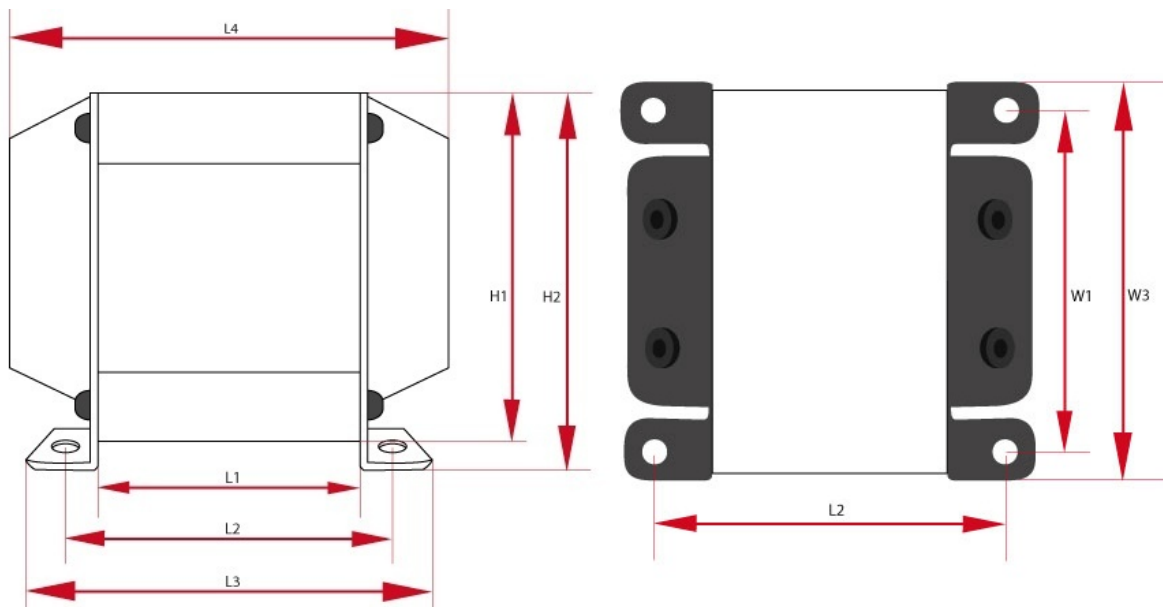

Power Transformer - TS80-2 - wersja z dwoma deklami (PL)							
P_{max}	U_{in}	F_z	Core	Size W	Size H	Size L	Weight
80 W	230 V	50 Hz	EI84/48	W1 - 110 mm W2 - 110 mm W3 - 110 mm	H1 - 110 mm H2 - 110 mm	L1 - 110 mm L2 - 110 mm L3 - 110 mm L4 - 110 mm	2 kg
U_{a1}	U_{a2}	U_{a3}	U_{a4}	U_{a5}	U_{a6}	U_{a7}	U_{a8}
250V/200mA	6,3V/2A	-	-	-	-	-	-
Oslona	Count						
OT10	1						

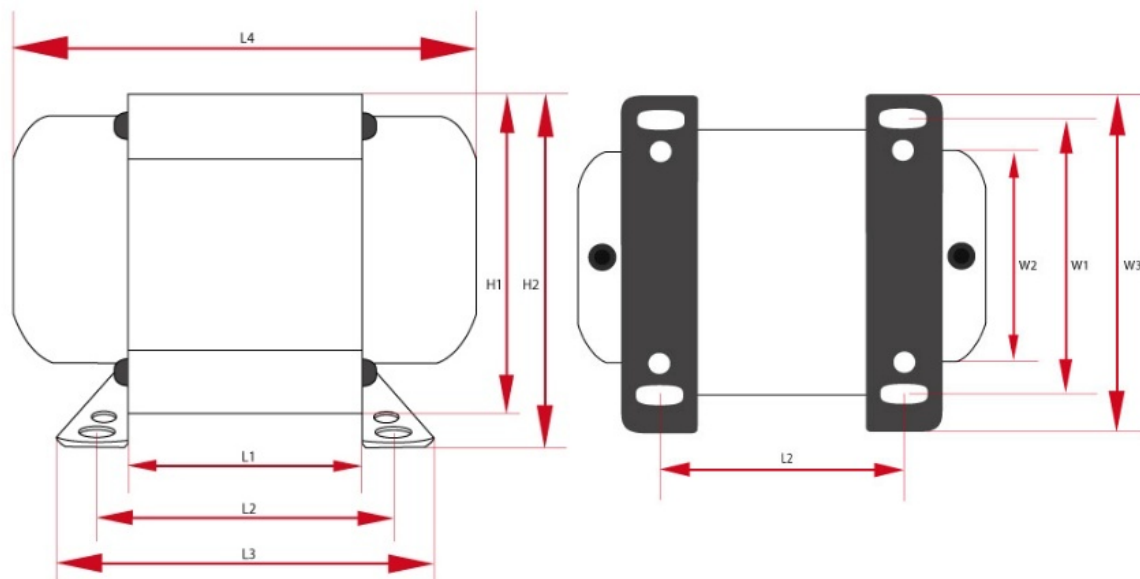

Power Transformer - TS80-2 - wersja z dwoma deklami (DE)

P_{max}	U_{in}	F_z	Core	Size W	Size H	Size L	Weight
80 W	230 V	50 Hz	EI84/48	W1 - 110 mm W2 - 110 mm W3 - 110 mm	H1 - 110 mm H2 - 110 mm	L1 - 110 mm L2 - 110 mm L3 - 110 mm L4 - 110 mm	2 kg
U_{a1}	U_{a2}	U_{a3}	U_{a4}	U_{a5}	U_{a6}	U_{a7}	U_{a8}
250V/200mA	6,3V/2A	-	-	-	-	-	-
Ostona	Count						
OT10	1						